

Installation Instructions

Norton® Automatic Door Operators 2000 Series

April 1, 1974

Regular Arm

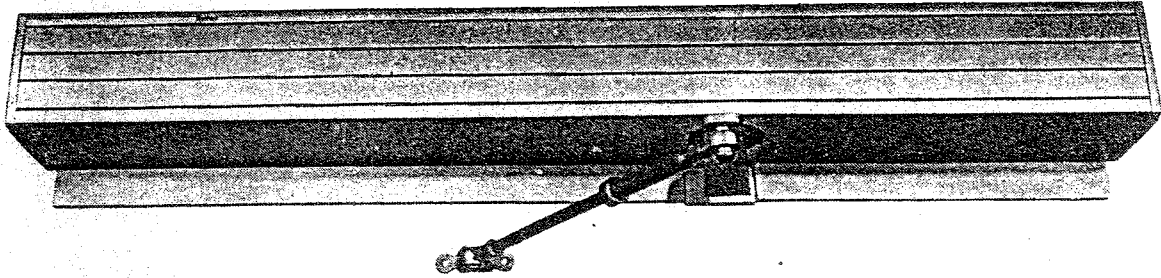

Parallel Arm

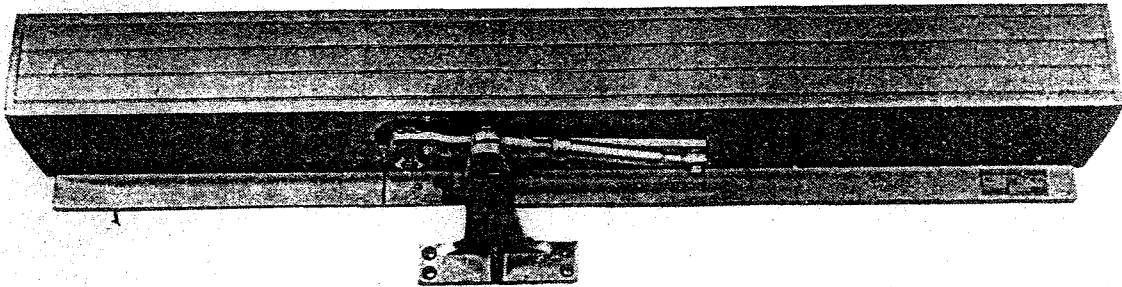

Parallel Arm with Panic Breakaway

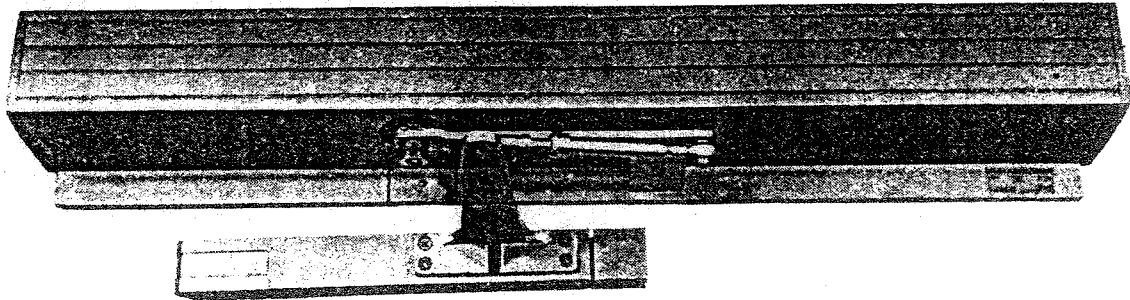

Slide Arm

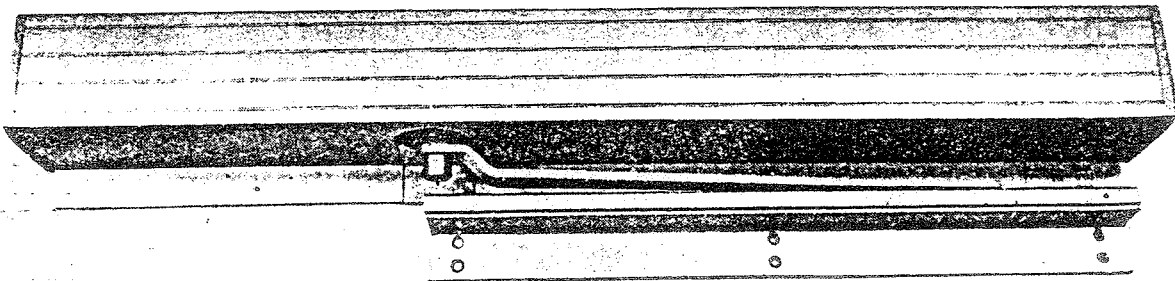

Index

Hand of Door Identification	1
Electrical Preparation	2
Back Plate Installation :	3
Operator Installation - Regular Arm	6
Operator Installation - Parallel & Slide Arm	8
Regular Arm Installation	10
Parallel Arm Installation	12
Manual Rotation of Operator Pinon	14
Parallel Installation with Panic Breakaway	16
Slide Arm Installation	18
Adjustment and Checkout	20
Cover Installation	24
Wiring Diagrams	

Read Installation Instructions **before** installing.

The sequence of installation and adjustment is in order, however some sections will not apply. Review this instruction manual and determine those sections that do apply.

Be sure all doors swing freely and clear all objects before attaching arms. Precaution must be made with parallel arms and adjacent walls.

Hand of Door Identification

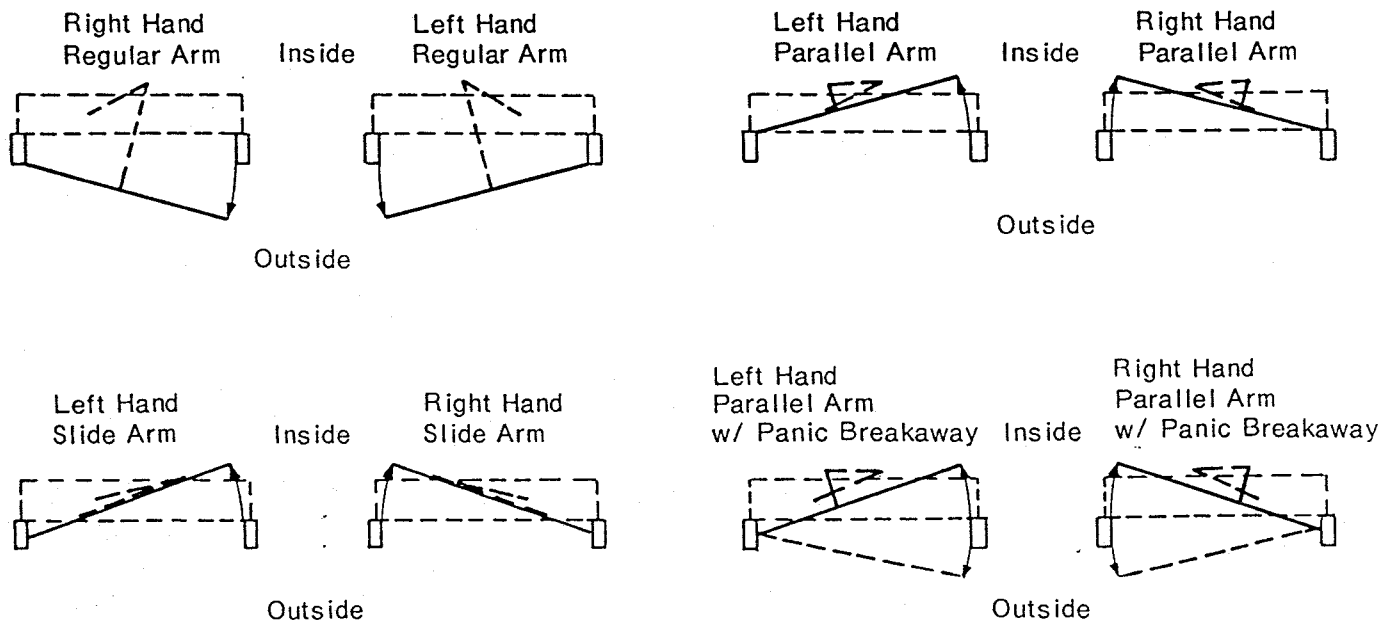

Preparation of Inside Face of Jamb

Before preparing jambs, determine the method and requirements for the electrical wiring involved and whether mats are used.

For mounting On-Off-Hold Open switch proceed to Operator installation section.

Caution: Some local electrical codes require On-Off-Hold Open switches to be not over 6'-6" above floor. A suggested method of installation is to prepare a 1 1/2" dia. hole as shown below. Using a 1 1/2" snap cover, drill a 1/2" dia. hole through center of cover. Assemble switch, drill #42 dia. hole for self tap screw. Install.

Preparation for Concealed Power Feed Lines

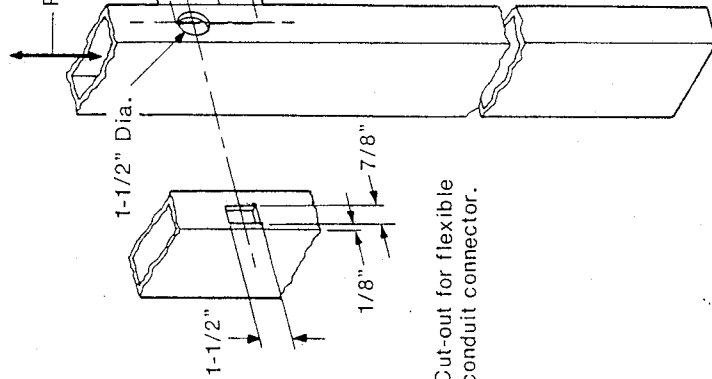

Electrical Power- Concealed

Run flexible conduit or 3-wire cable down side jamb, through cut-out. Trim sufficient length of wire and insert into 90° connector. Attach connector to connector bracket and secure with lock nut. Trim to proper length when wiring unit.

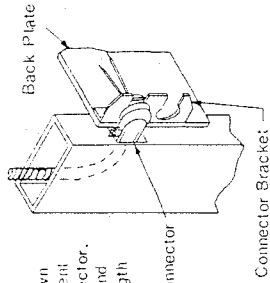

Preparation for Concealed Mat Lead Lines

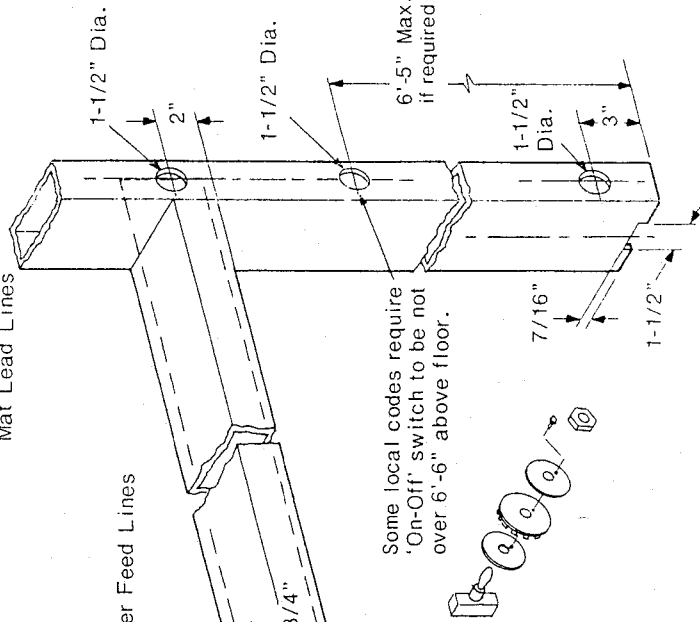

Either jamb may be prepared for power or mat lead wires.

Electrical Preparation

Electrical Power- Surface Mounted Conduit

Connect 90° elbow to bracket as shown, pull sufficient length of wire. Trim to proper length when wiring unit.

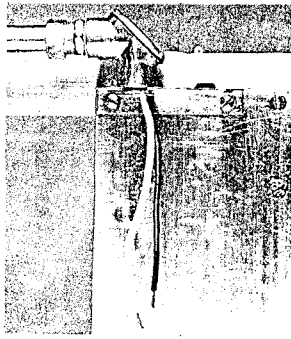

Electrical Power- Surface Mounted Romex

Trim sufficient length of wire, insert into wire connector. Attach connector to connector bracket and secure with lock nut. Trim wire to proper length when wiring unit.

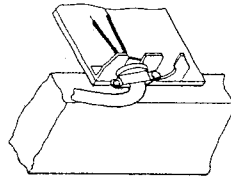

Electrical Power- Power Cord

Power cord installation available by special order where local electrical codes permit. Insert grommet furnished on the power cord into the connector bracket, either end of the operator convenient to power outlet.

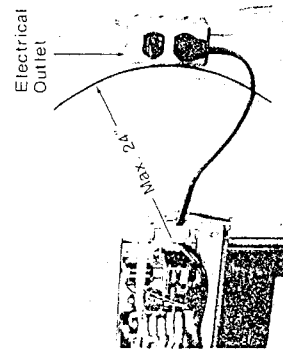

Back Plate Installation

Before preparing jamb for the Back Plate determine the Hand of the Door. If door hand is L.H. Regular or R.H. Parallel proceed as shown. If door hand is R.H. Regular or L.H. Parallel reverse the Back Plate end to end so that it is opposite as shown. See inside front cover for Hand of Door Identification.

Hole Instructions

For Metal Frames with 1/8" surface thickness Drill #7 hole and Tap for 1/4-20 x 3/4" machine screw as required. For Metal Frames with less than 1/8" surface thickness or Wood Frames, Drill 3/16" pilot hole for #14 x 1 1/4" sheet metal screw as required.

Mounting Back-Plate

Mount to prepared jamb using furnished flat head screws suitable to prepared holes.

For Swing Clear Hinges- Place end of Back Plate 7/8" out beyond the center-line of hinge pin or order special length back plate and cover.

See Installation of Covers and Back Plates of a different length than door opening, page 4.

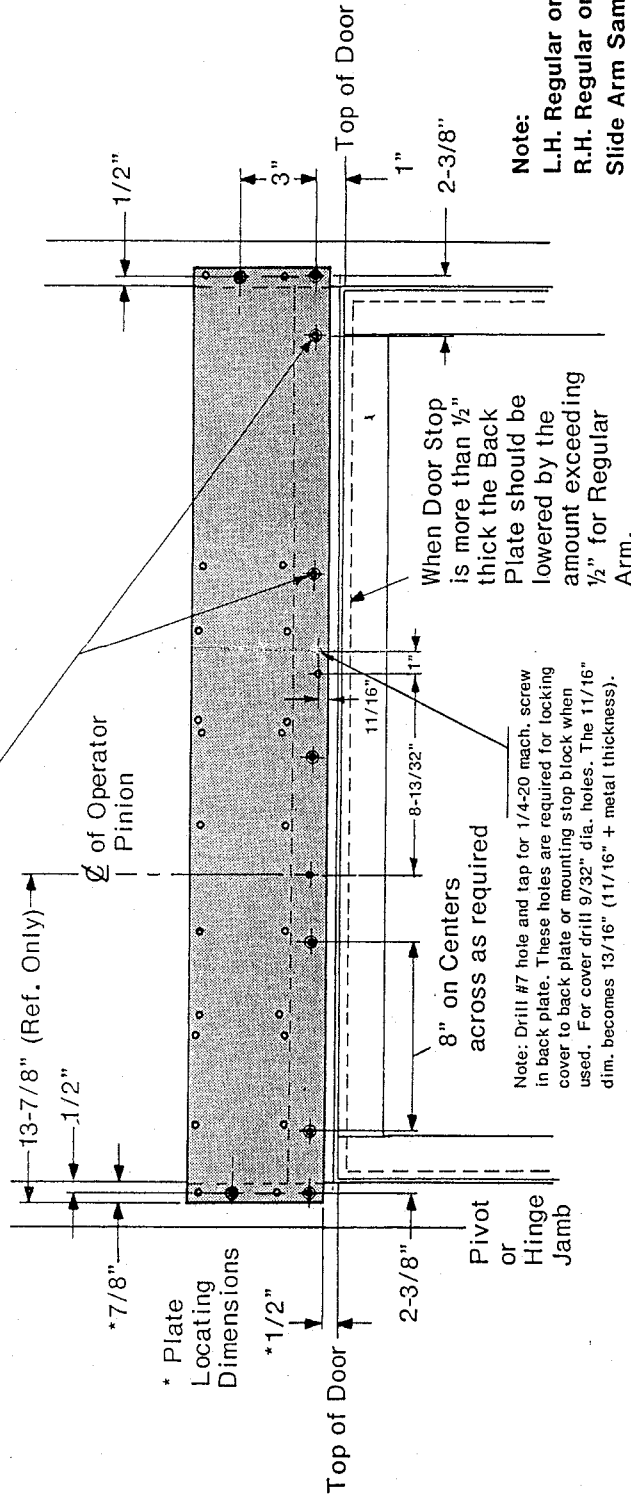

Note:

L.H. Regular or R.H. Parallel Shown
R.H. Regular or L.H. Parallel Opposite
Slide Arm Same as Parallel Arm

Back Plate Anchorage

Aluminum Frame

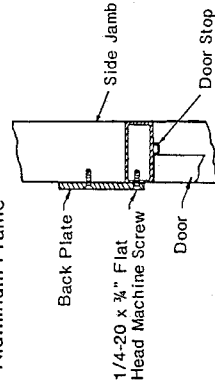

Hollow Metal Frame

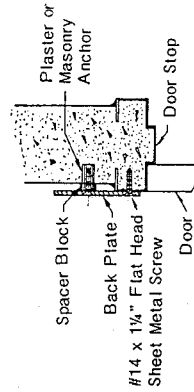

Wood Frame

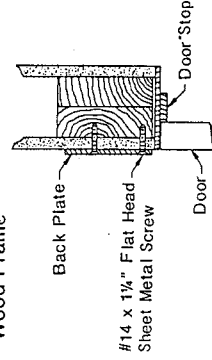

Dual Back Plate Installation

Mounting two (2) operators and control(s) over a pair of doors is usually done on one piece back plate with one cover. The mounting procedure is the same as for a single unit. See Back Plate Installation.

Two single units may be butted together to make a dual combination. Removal of the cover end caps is necessary to allow the butting of the units.

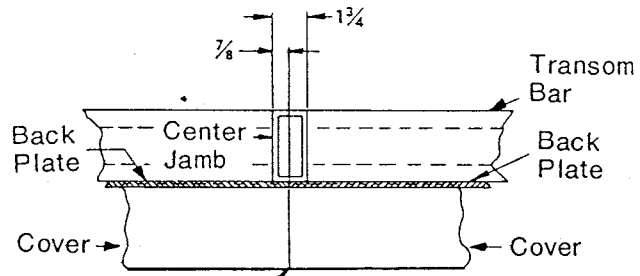
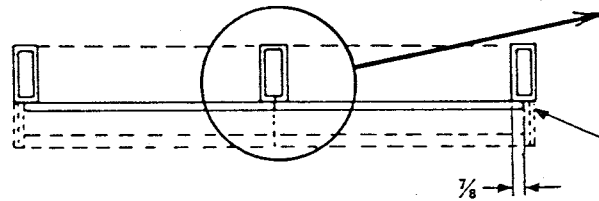
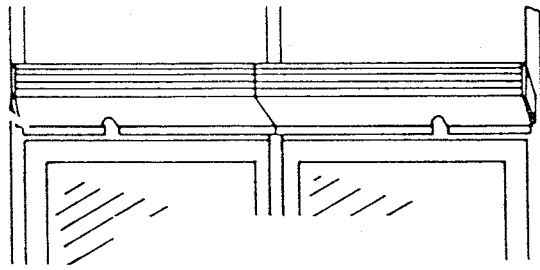

Butt both Back plates and both operator covers together.

Back plates and covers must over-lap side jambs as shown on each end.

Installation of Covers and Back plates of a different length than Door Opening

1. Mounted as is

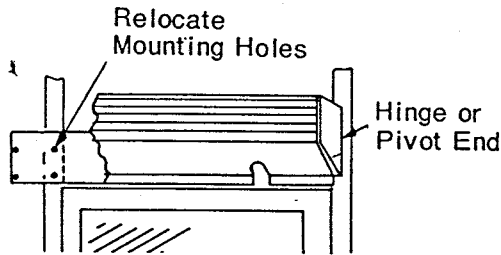

Note:
In all installations the back plate must over-lap the hinge jamb 7/8".

2. Cut to door size

If no over-lap is desired, measure and cut Back plate and cover as shown.

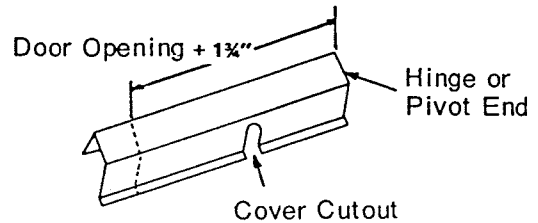
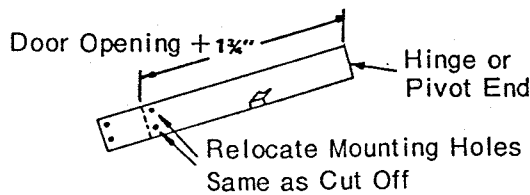

3. Cut under door size

When the Back plate is shorter than the width of door, an angle bracket should be installed the full length of the Back plate.

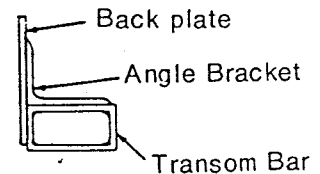
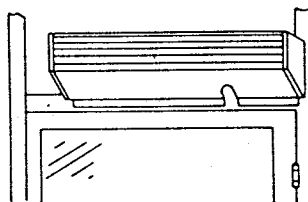

Alternate Position for On-Off-Hold Open Switch

Cut out bottom corner as shown nearest to the location of controls for single operators or cut out bottom corners toward the center for dual operators.

SINGLE OPERATOR

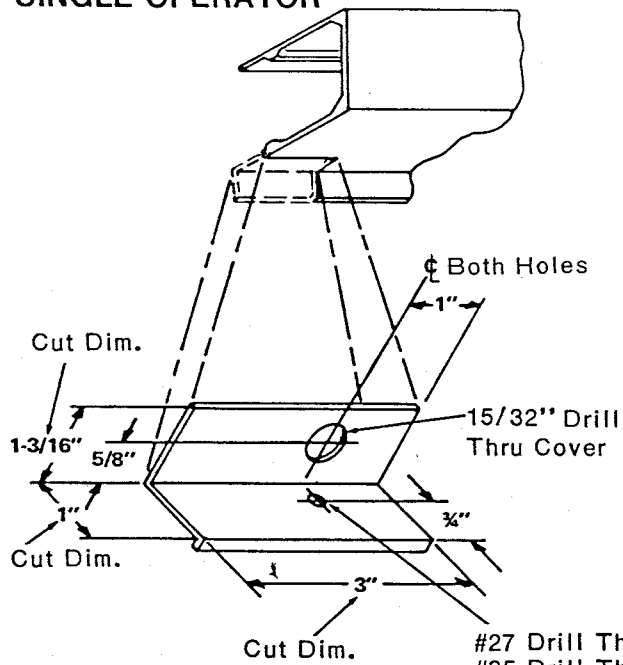

DOUBLE OPERATOR

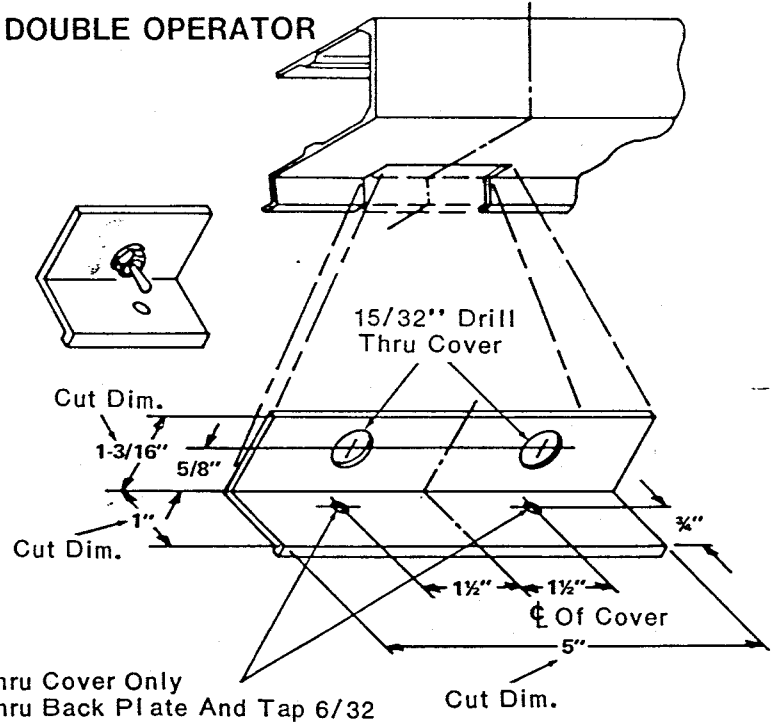

Operator Installation Regular Arm

Mounting Operator

Right Hand Shown, Left Hand Opposite

Mount operator to back plate using 1/4-28 fillister head screws with lockwashers as shown.

Mount connector brackets each end of back plate using 1/4-28 fillister head screws with lockwashers as shown.

1/4-28 x 3/8" Fillister Head Machine Screw
1/4" Lockwasher

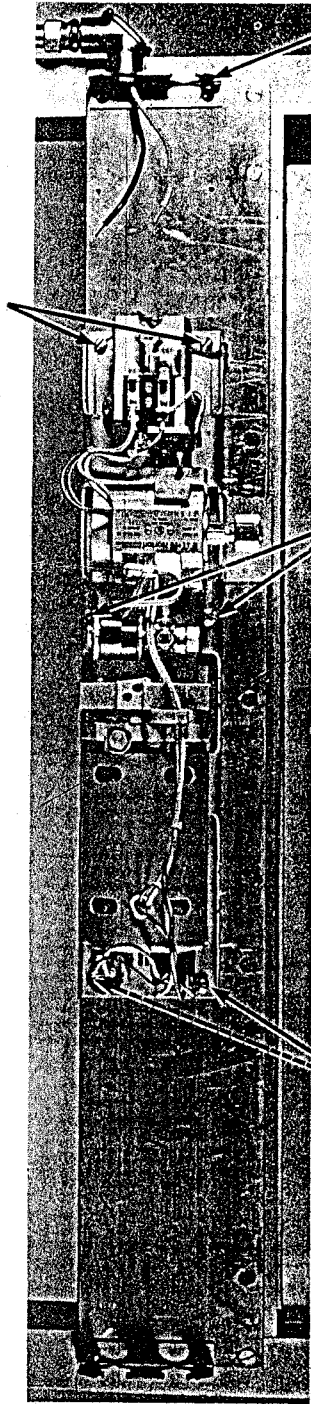

1/4-28 x 3/8" Fillister Head Machine Screw
1/4" Lockwasher

1/4-28 x 1-1/4" Truss Head Machine Screw
1/4" Flat Washer
1/4" Lockwasher

Connector Bracket
1/4-28 x 3/8" Fillister Head Machine Screw
1/4" Lockwasher
(Both Ends)

Mounting Control Unit

Mount control unit to back plate using (4) 8-32 mach. screws with standoffs and washers.

Caution- Be sure the words "Mercury Relay" on mercury relay are upright. If it is not, the relay must be reversed by removing attaching screws.

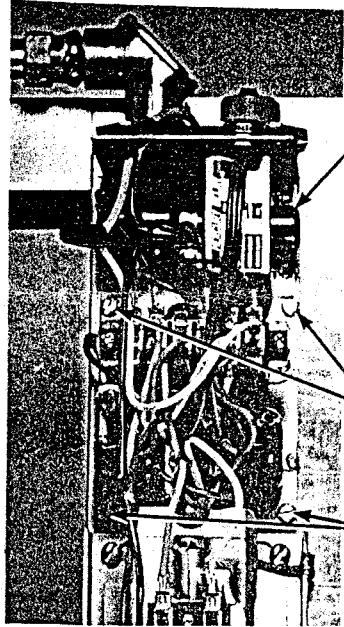
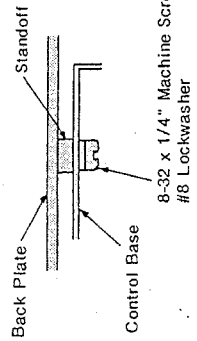

8-32 x 1/4" Pan Head Phillips Machine Screw
#8 Internal Tooth Lockwasher
Nylon Standoff
Mercury Relay

Operator Installation Regular Arm (cont'd.)

Mounting On-Off-Hold Open Switch

Disassemble On-Off-Hold Open switch and mount to connector bracket as shown.

Caution- some local electrical codes require the On-Off-Hold Open switch to be located 6'-6" above floor. See Electrical Preparation section, page 2.

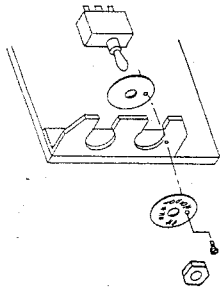

On-Off-Hold Open Switch Assembly

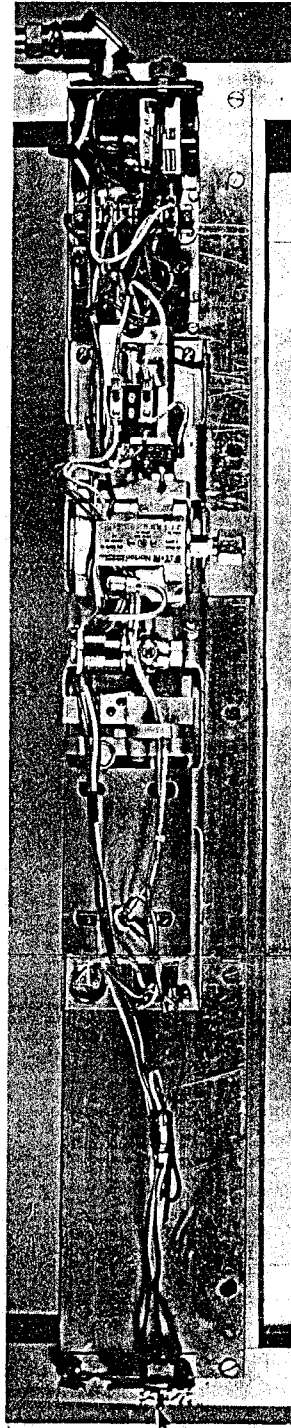

On-Off-Hold Open Switch

Installing Mat Lead Wire

Insert grommet on mat lead wire into connector bracket. Feed mat lead wire down the side jamb for mat lead connection. See Mat Installation Instructions.

Trim 110 volt 60 hertz power line wires to proper length, connect white to white and black to black with wire nuts. Connect white wire from control unit onto operator terminal P1 and orange wire onto P2. Bundle up excess wire and tape so that the excess wire will not interfere with operation of operator and cover.

Wire Nut

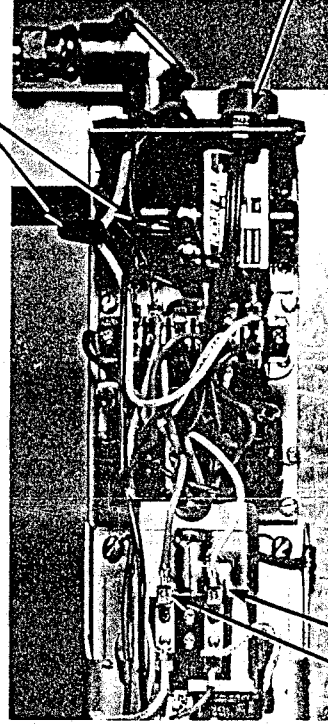

Mat Lead Wire Grommet

P1 P2

Operator Installation Parallel & Slide Arm

Mounting Operator Right Hand Shown, Left Hand Opposite

Mount operator to back plate using 1/4-28 fillister head screws with lockwashers as shown.

Mount connector bracket each end of back plate using 1/4-28 fillister head screws with lockwashers as shown.
Note: Bracket on top of operator end mounts on top of shock mount base.

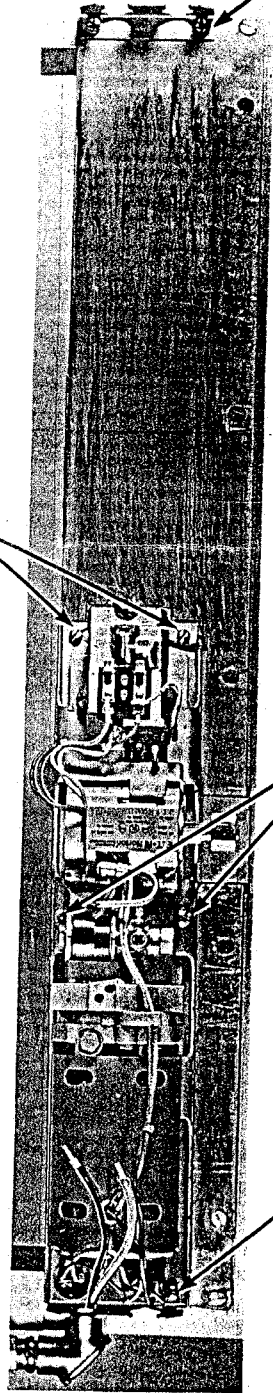

1/4-28 x 3/8" Fillister Head Machine Screw
1/4" Lockwasher

Connector Bracket
1/4-28 x 3/8" Fillister Head Machine Screw
1/4" Lockwasher

1/4-28 x 1-1/4" Truss Head Machine Screw
1/4" Flat Washer
1/4" Lockwasher

Connector Bracket
1/4-28 x 3/8" Fillister Head Machine Screw
1/4" Lockwasher

Mounting Control Unit

Mount control unit to back plate using (4) 8-32 mach. screws with standoffs and washers.

Caution- Be sure the words "Mercury Relay" on mercury relay are upright. If it is not, the relay must be reversed by removing attaching screws.

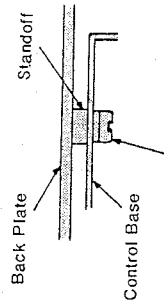

8-32 x 1/4" Machine Screw
#8 Lockwasher



8-32 x 1/4" Pan Head Phillips Machine Screw
#8 Internal Tooth Lockwasher
Nylon Standoff

Mercury Relay

Operator Installation Parallel & Slide Arm (cont'd)

Mounting On-Off-Hold Open Switch

Disassemble On-Off-Hold Open switch and mount to connector bracket as shown.

Caution- some local electrical codes require the On-Off-Hold Open switch to be located 6'-6" above floor. See Electrical Preparation section, page 2.

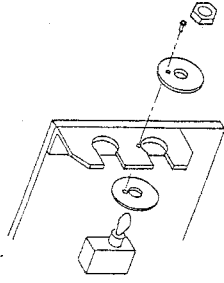

On-Off-Hold Open Switch Assembly

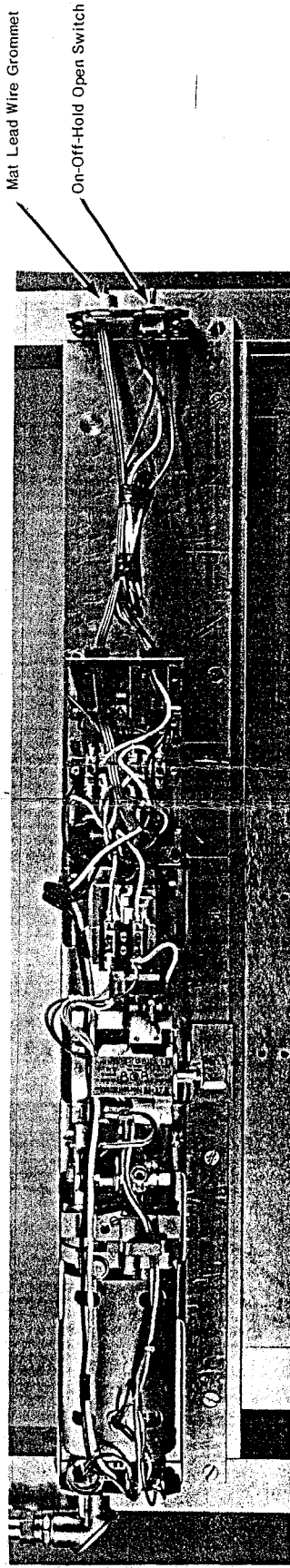

Mat Lead Wire Grommet

On-Off-Hold Open Switch

Wire Nut

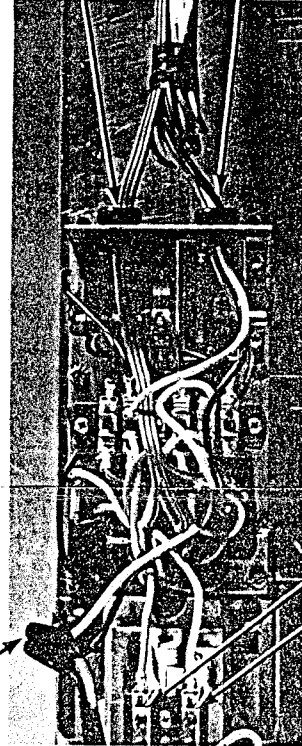

Mat Lead Wire with Grommet

On-Off-Hold Open Wiring with Grommet

P1 P2

Installing Mat Lead Wire

Insert grommet on mat wire into connector bracket. Feed mat lead wire down the side jamb for mat lead connection. See Mat Installation Instructions.

Trim 110 volt 60 hertz power line wires to proper length, connect white to white and black to black with wire nuts. Connect white wire from control unit onto operator terminal P1 and orange wire onto P2. Bundle up excess wire and tape so that the excess wire will not interfere with operation of operator and cover.

Regular Arm Installation

Hand of Door Identification

Identify hand of door before proceeding.
See inside front cover, page 1.

Door frame must have Door Stop

Door Preparation for Regular Arm

Right Hand shown, Left Hand opposite

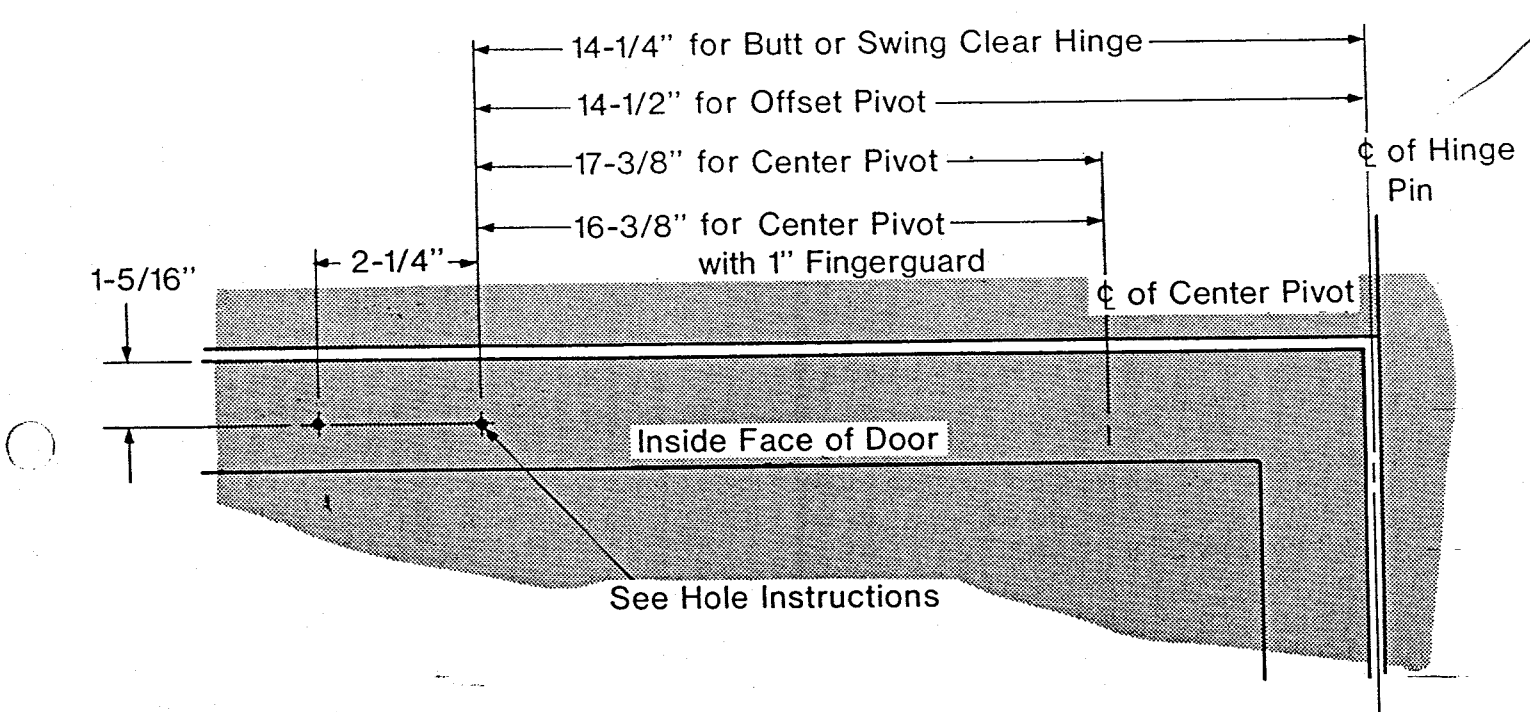

Hole Instructions

For **Metal Doors** with 1/8" surface thickness
Drill #7 hole and Tap for 1/4-20 x 5/8" machine
screw (2 holes). For **Metal Doors** with less
than 1/8" surface thickness or **Wood Doors**
Drill 3/16" pilot hole for #14 x 1/4" sheet
metal screw (2 holes).

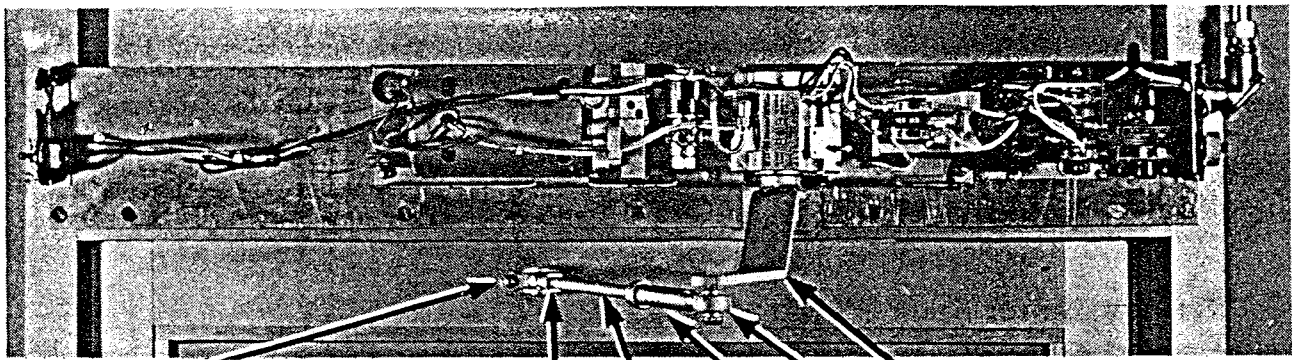

- Shoe
- 1/4-20 x 5/8" Round Head Machine Screw
or #14 x 1/4" Round Head Sheet Metal Screw
- Rod End
- Sleeve
- Main Arm
- Secondary Rod
- Rod End

Mounting Regular Arm

1. Assemble Secondary Sleeve onto Rod End which is attached to main arm, screw all the way in.
2. Place Main Arm on Pinon Shaft of operator indexing as shown. Replace locking pinon nut, tighten.
3. Mount Shoe to door using furnished screws suitable to prepared holes. **Note:** The keyed hole (with flat spot) must go down.
4. Determine Depth of Reveal. Using Table, cut secondary rod to proper length. Insert rod into secondary sleeve, bottom and finger tighten set screw with 3/16" allen wrench.

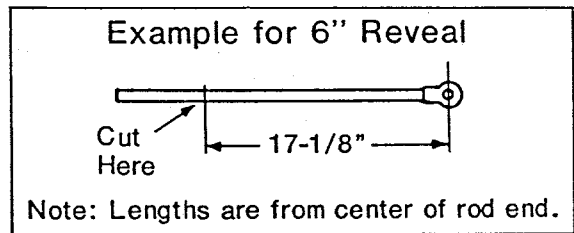
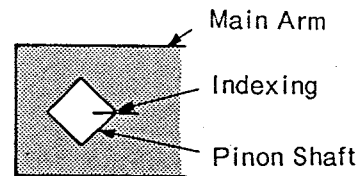
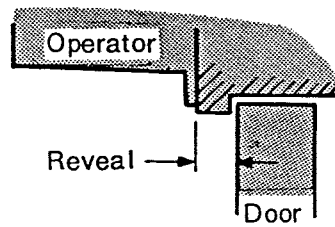

Table for Cutting Rod Length

Reveal	Center Pivot	Butt Hinge	Offset Pivot
0 to 2-7/8"	12-7/8"	11-1/8"	11-3/8"
3" to 5-7/8"	15-1/2"	14-1/8"	14-3/8"
6" to 8-7/8"	18-3/8"	17-1/8"	17-3/8"
9" to 11-7/8"	21-1/4"	20-1/8"	20-3/8"
12" to 12-1/4"	21-3/8"		
12" to 13"		21-3/8"	21-3/8"

Note: Any reveals greater than these require special parts and instructions. Contact Norton Marketing Department.



5. Slide Rod End of secondary arm into Shoe. Drop sex bolt through hole in shoe and rod end. Insert screw into bottom of sex bolt, tighten.

Adjustment

With door against door stop and set screw in sleeve loosened, rotate main arm 7° as shown. Tighten set screw.

Suggestion- loosen set screw and remove secondary rod from sleeve, file flat spot at place of indentation of screw, replace, readjust and tighten.

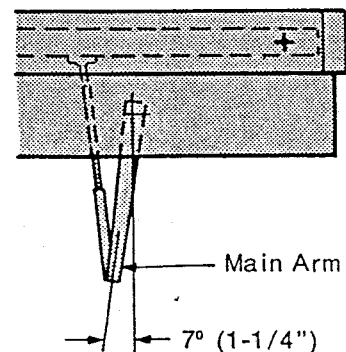

Parallel Arm Installation

(Revised 6-74)

Hand of Door Identification

Identify hand of door before proceeding.
See inside front cover, page 1.

Caution- Before proceeding with preparation of door, determine the depth of reveal. See Table below.

Door Preparation for Parallel Arm

Right Hand Shown, Left Hand Opposite.

Door frame must have Door Stop

Table for Hole Location

Depth of Reveal	Center Pivot	Center Pivot w/ 1" Fingerguard	Butt Hinge	Offset Pivot 3/4"
0 to 1"	9-1/2"	9-1/2"	10-1/16"	10-1/16"
1-1/16" to 2-1/2"	9-1/2"	9-1/2"	10-1/4"	10-3/8"
2-9/16" to 4"	6-7/8"	6-7/8"	8-1/8"	8-1/8"
4-1/16" to 5"	6-3/4"	6-5/8"	8-1/8"	8-1/8"
5-1/16" to 6"	6-1/2"	6-3/8"	8"	8"

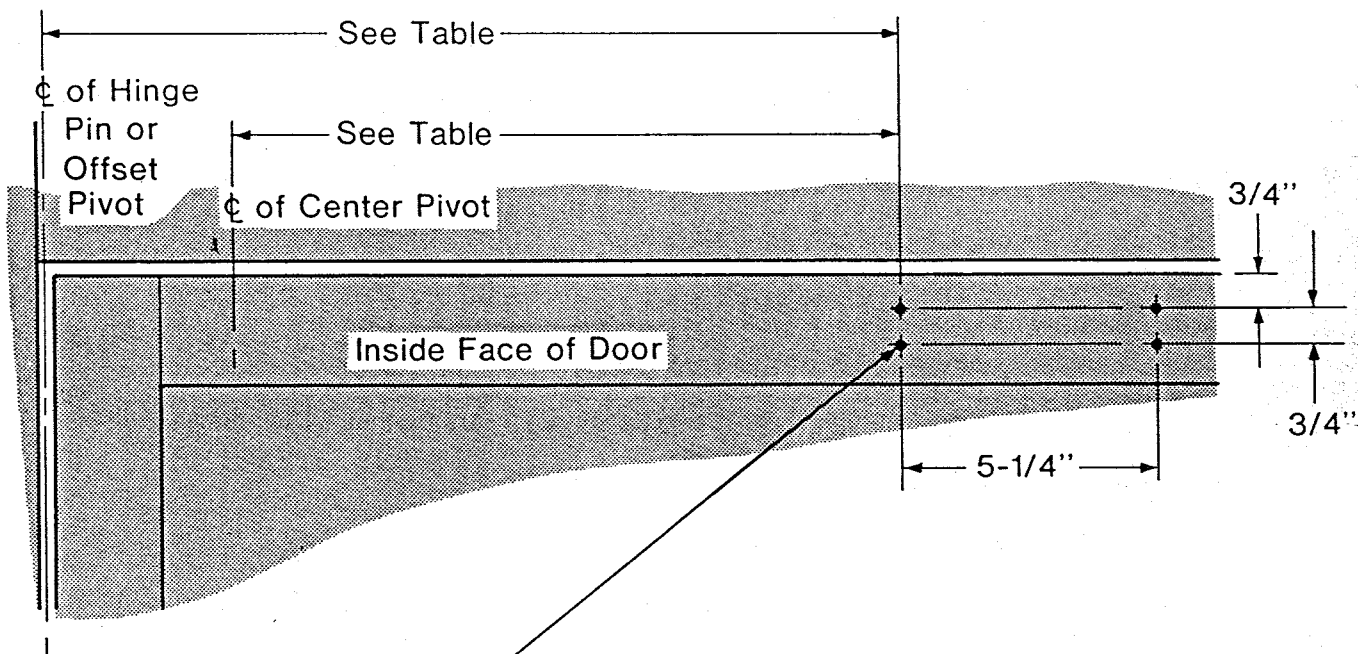

Hole Instructions

For **Metal Doors** with 1/8" surface thickness
Drill #7 hole and Tap for 1/4-20 x 5/8" machine
screw (4 holes). For **Metal Doors** with less
than 1/8" surface thickness or **Wood Doors**
Drill 3/16" pilot hole for #14 x 1/4" sheet
metal screw (4 holes).

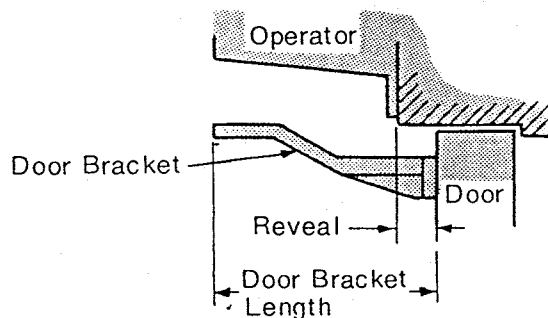

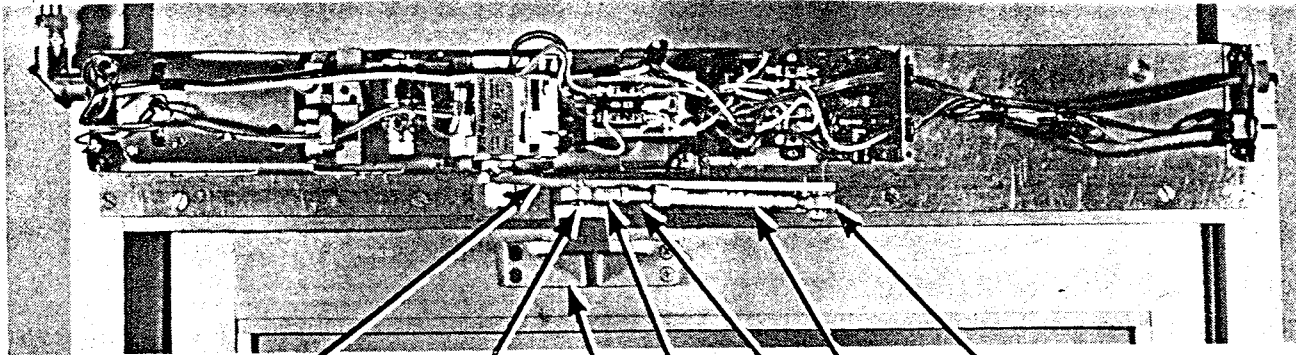

Main Arm Stud Screw Rod End Sleeve Rod End

1/4-20 x 5/8" Round Head Machine Screw
or #14 x 1 1/4" Round Head Sheet Metal Screw

Mounting Parallel Arm

1. Assembly Secondary Sleeve onto Rod End which is attached to main arm. screw all the way in.
2. Place Main Arm on Pinon Shaft of operator indexing as shown. Replace locking pinon nut, tighten. See page 14 for rotating operator pinon manually.
3. Insert Stud Screw into hole nearest end of door bracket, (see illustration), stake or use liquid staking before inserting or use sheet metal lock nut. Mount Door Bracket to door using furnished screws suitable to prepared holes. See Table in Door Preparation for proper door bracket.
4. Determine depth of reveal. Using Table, cut secondary rod to proper length. Insert rod into secondary sleeve, bottom and finger tighten set screw with 3/16" allen wrench.

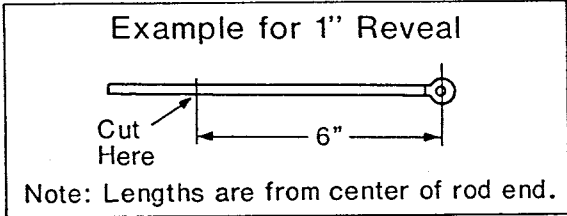
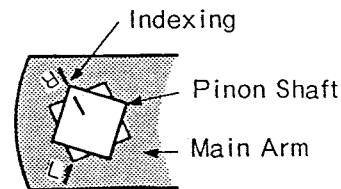
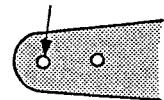

Table for Cutting Rod Length

Depth of Reveal	Center Pivot	Center Pivot w/ 1" Fingerguard	Butt Hinge	Offset Pivot	Door Bracket Length Used
0 to 2-1/2"	6"	5"	7-3/4"	7-1/4"	7"
2-9/16" to 6"	9"	8"	10-1/4"	9-1/2"	11"

Note: Any reveal greater than 6" requires a special bracket and special instructions. Contact Norton Marketing Department.

Use this hole
Step 3



Door Bracket

5. Place Rod End onto Stud on Door Bracket, insert screw, tighten.

Adjustments

With door against door stop and set screw in sleeve loosened, rotate main arm to 1 1/4" from back plate as shown. Tighten set screw.

Suggestion- loosen set screw and remove secondary rod from sleeve, file flat spot at place of indentation of screw, replace, readjust and tighten.

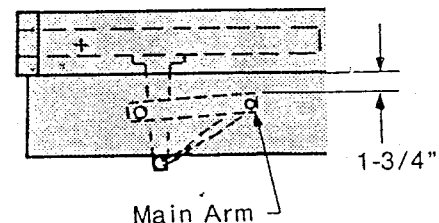

Manual Rotation Operator Pinon

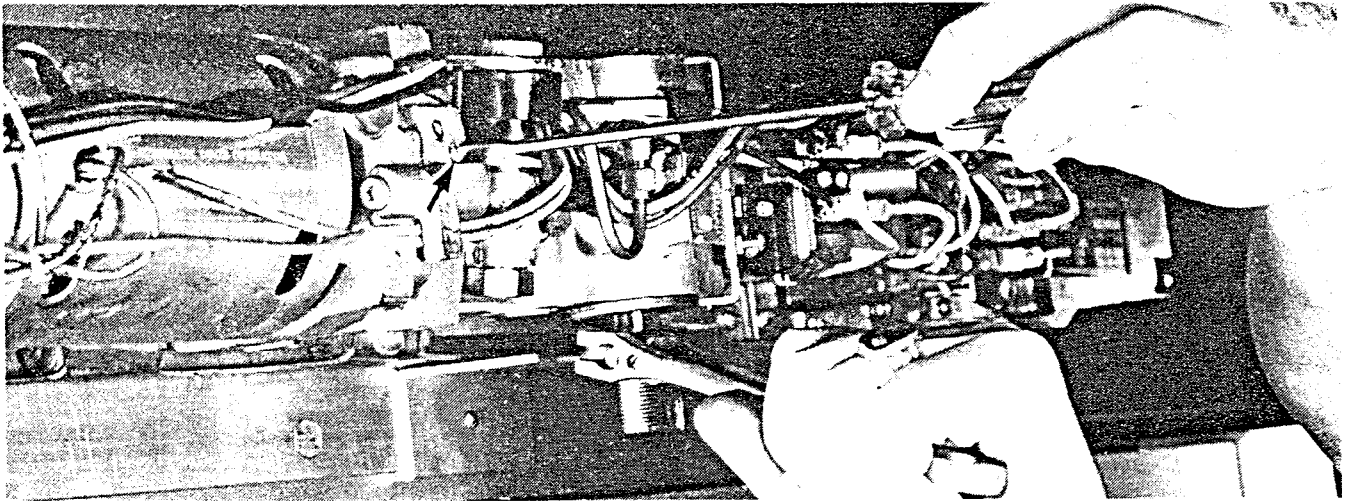

1. Using the main arm or an open end wrench, rotate pinon of operator approx. $\frac{1}{4}$ of a turn, hold in that position.
2. Using a narrow bitted screwdriver, turn sweep valve clockwise and bottom on the seat, do not tighten.
3. Remove main arm or open end wrench and proceed to install main arm.
4. After installation of arm to door, return sweep valve to approx. original position. Final adjustment will be made in Adjustments and Checkout procedures.

Parallel Arm Installation with Panic Breakaway

Hand of Door Identification

Identify hand of door before proceeding.
See inside front cover, page 1.

Caution- Before proceeding with preparation of door, determine the depth of reveal. See Table below.

Door Preparation for Panic Breakaway

Right Hand Shown, Left Hand Opposite

Door must be center pivoted or be capable of swinging in both directions.

Table for Hole Location

Depth of Reveal	Dim "A"	Door Bracket Length Used
0 to 2-1/2"	9-3/4"	7"
2-9/16" to 4"	7-1/8"	11"
4-1/16" to 5"	7"	
5-1/16" to 6"	6-3/8"	

Note: Any reveal greater than 6" requires a special bracket and special instructions. Contact Norton Marketing Department.

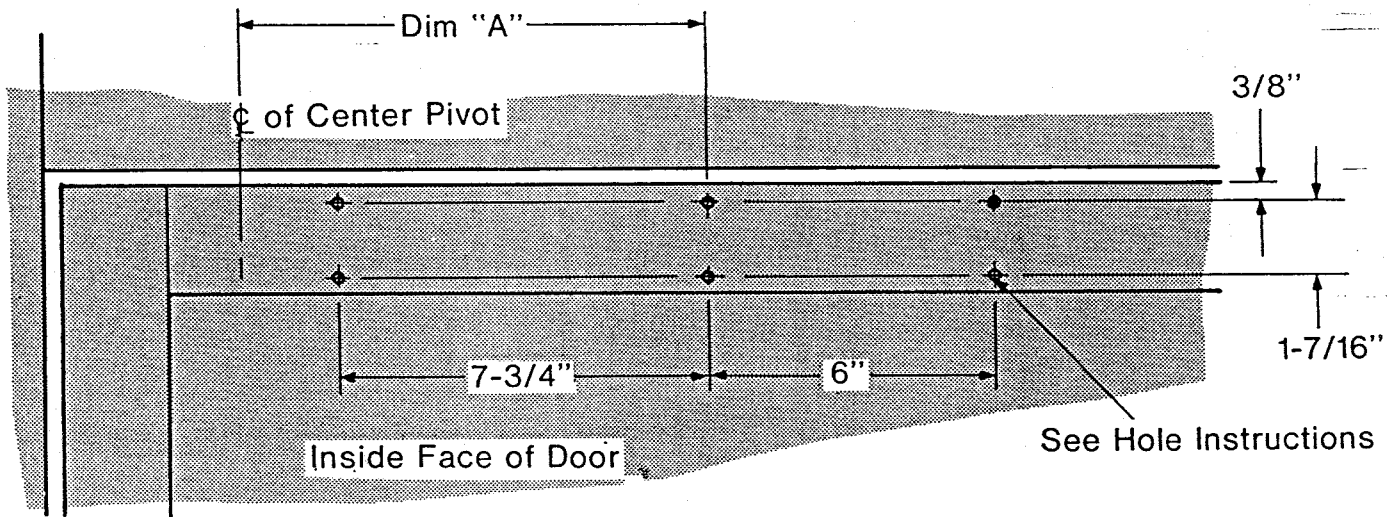
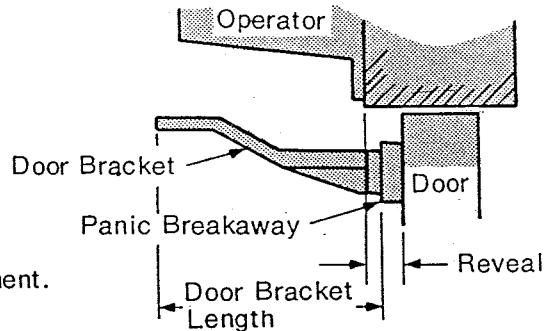

Hole Instructions

For **Metal Doors** with 1/8" surface thickness
Drill #7 hole and Tap for 1/4-20 x 5/8" machine screw (6 holes). For **Metal Doors** with less than 1/8" surface thickness or **Wood Doors**
Drill 3/16" pilot hole for #14 x 1/4" sheet metal screw (6 holes).

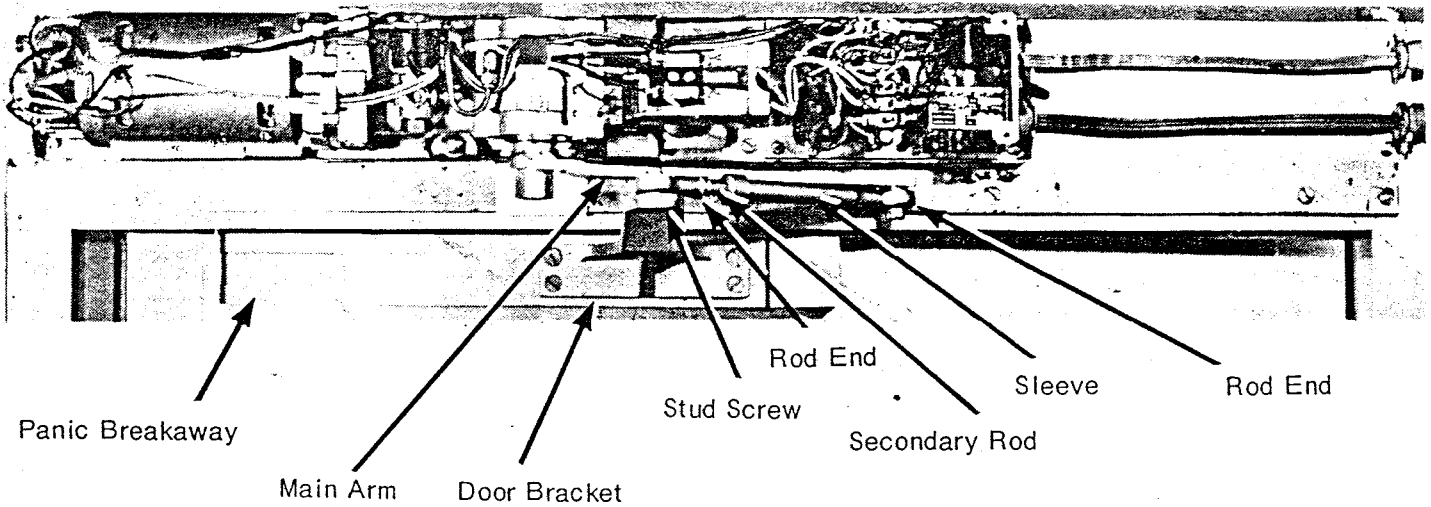

Mounting Panic Breakaway

Mount to prepared door using 1/4-20 x 3/4" flat head machine screws or #14 x 1-1/4" flat head sheet metal screws suitable to prepared holes.

Use this hole
Step 3

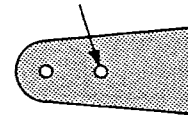

Door Bracket

Mounting Parallel Arm

1. Assembly Secondary Sleeve onto Rod End which is attached to main arm, screw all the way in.
2. Place Main Arm on Pinon Shaft of operator indexing as shown. Replace locking pinon nut, tighten. See page 14 for rotating operator pinon manually.
3. Insert Stud Screw into second hole from the end of Door Bracket, stake or use liquid staking before inserting. Mount Door Bracket to Panic Breakaway using 1/4-20 x 5/8" Oval head machine screws. See Table in Door Preparation for proper bracket.
4. Determine Reveal. Using Table, cut Secondary Rod to proper length. Insert rod into Secondary Sleeve, bottom and finger tighten set screw with 3/16" allen wrench.
5. Place Rod End onto Stud on Door Bracket, insert screw, tighten.
6. Mount Arm Stop to back plate temporary using 1/4-20 x 1 3/4" oval head machine screws. Note: Stop block is tapered to match contour of arm main.

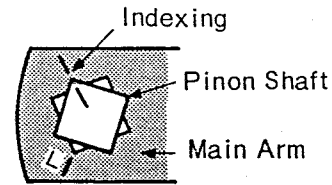

Example for 1" Reveal

Note: Lengths are from center of rod end.

Table for Cutting Rod Length

Reveal	Cut Rod Length
0 to 2-1/2"	5"
2-9/16" to 6"	8-1/4"

Adjustments

Loosen set screw, center door in frame with main arm in contact with stop block, tighten set screw. Do not set, will require final adjustment after installation of cover.

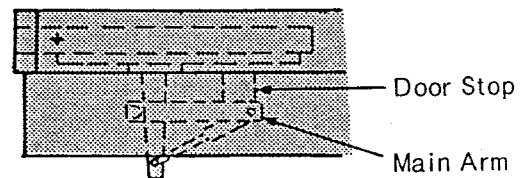

Slide Arm Installation

Hand of Door Identification

Identify hand of door before proceeding.
See inside front cover, page 1.

Door frame must have Door Stop

Door Preparation for Slide Arm

Right Hand Shown, Left Hand Opposite

Door Opening Width	Dim. "A"
30" to 35-1/4"	5-3/4"
35-1/2" to 48"	11"

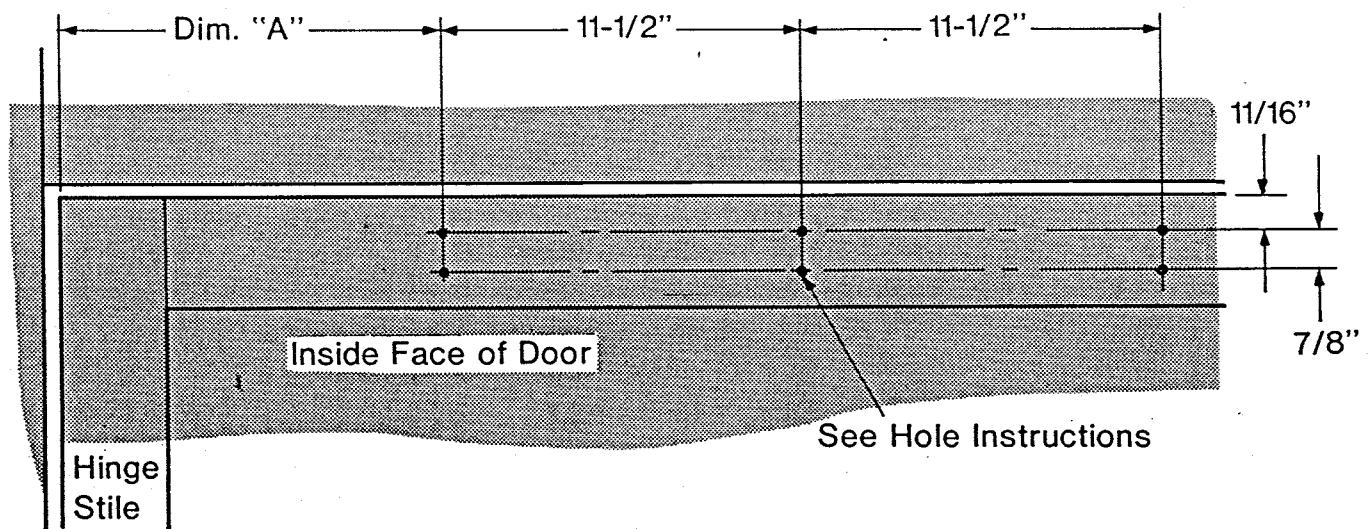

Hole Instructions

For **Metal Doors** with 1/8" surface thickness
Drill #7 hole and Tap for 1/4-20 x 5/8" machine
screw (6 holes). For **Metal Doors** with less
than 1/8" surface thickness or **Wood Doors**
Drill 3/16" pilot hole for #14 x 1/4" sheet
metal screw (6 holes).

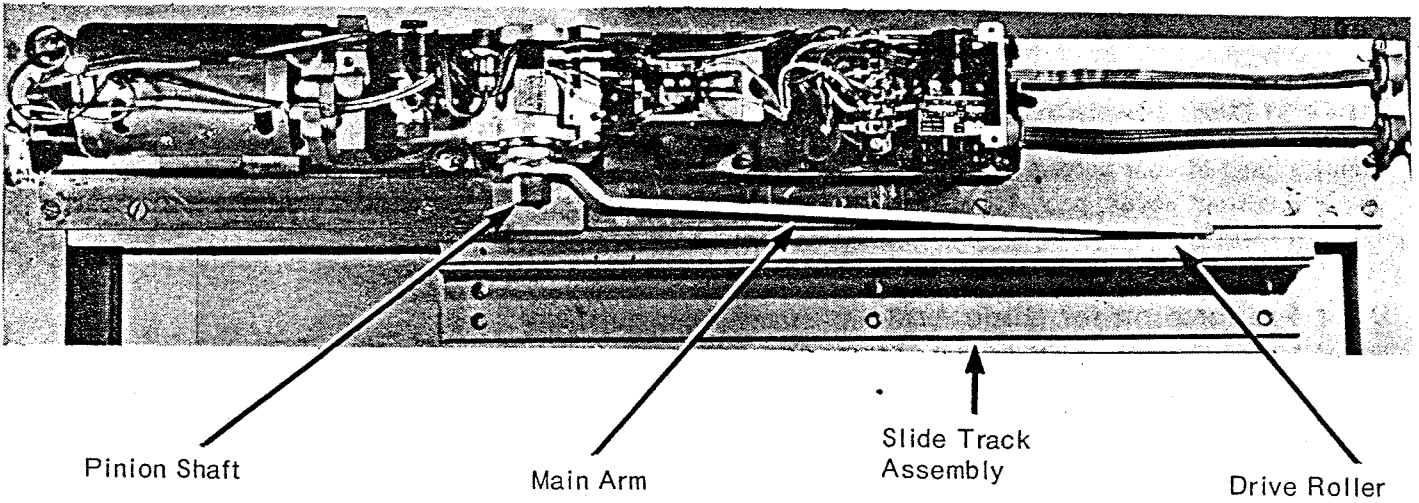

Mounting Slide Arm

1. Insert Stud into Drive Roller, screw stud into threaded hole in Side Arm as shown on opposite side of the bend in the arm. Stake with a center punch or use liquid staking before assembling.
2. Place Slide Arm on Pinon Shaft of operator indexing as shown. Replace locking pinon nut, tighten. See page 14 for rotating operator pinon manually.
3. Slide track assembly onto drive roller. Mount track assembly to door using furnished screws suitable to prepared holes.

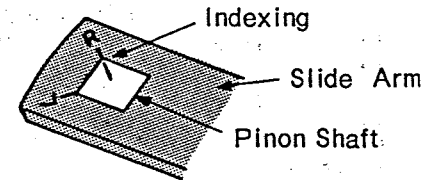
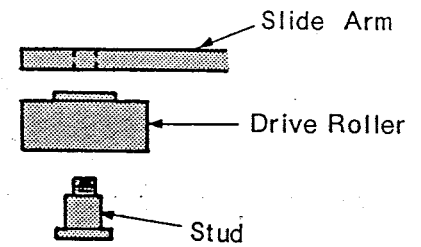

Note: Slide Arm may need field alignment to relieve any strain or excess rubbing of roller or arm on track.

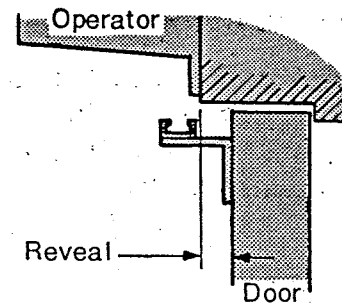

Table for Slide Kit Selection

Reveal	Door Opening Width	Slide Kit Number	Angle Bracket	Overall Arm Length
0 to 1/2"	30" to 35-1/4"	44-2000-0051	2"x2"	17-1/2"
0 to 1/2"	35-1/2" to 48"	44-2000-0054	2"x2"	20-1/2"
9/16" to 1-1/2"	30" to 35-1/4"	44-2000-0052	3"x2"	17-1/2"
9/16" to 1-1/2"	35-1/2" to 48"	44-2000-0055	3"x2"	20-1/2"

Adjustment and Checkout Speed and Pressure

Important

Make all tests of the functions of the operator using operational switching devices such as mats, photoelectric or wall switches and the on-off-hold open switch.

As the unit warms up to operating temperature, operating speeds will increase, therefore the speed must be set slower than normally desired.

Timing of Door Swing

The time of swing of an average size and weight door (80 to 150 lbs.) from moment of start and until the door reaches the backcheck position shall **not** be less than 1½ seconds and it shall **not** be less than 1¾ seconds to full 90% opening. Doors larger and heavier should be set to operate slower in opening and closing cycles.

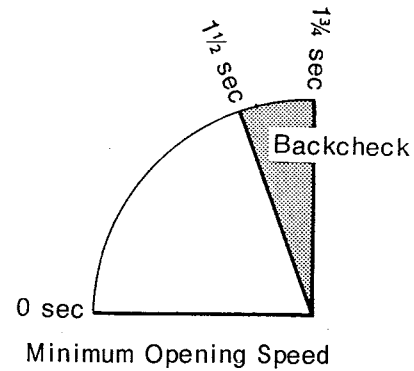

Speed Adjustment

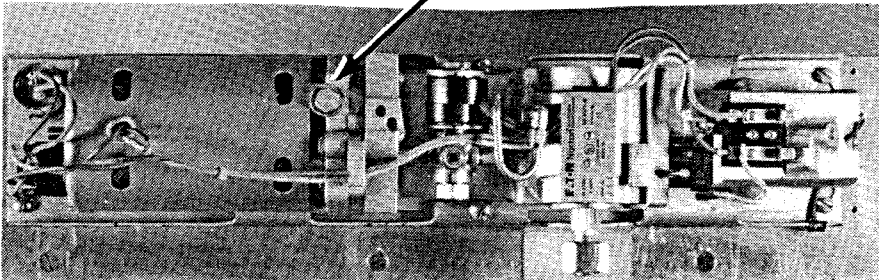

Adjustment

To adjust speed, remove hex. cap plug with 6 sided box end wrench or socket. Do not use an open end wrench or 12 pointed wrench. Turn counterclockwise. Using 3/16" allen wrench, turn allen set screw clockwise to increase speed. Turn counterclockwise to decrease.

Note: When making speed adjustment on operator, it is not necessary to replace the hex. cap plug after each adjustment attempt.

After the proper speed has been determined, replace cap plug. Tighten, do not overtighten. Be sure that the cap plug does not bottom with adjustment screw.

If it was necessary to increase the pressure, make sure that the unit is not over-adjusted and overloads the motor. To check for overloading, block or hold the door in a half open position (approx. 45%). With the operator turned on, if the motor lopes, jerks, or growles, the pressure has been raised too high. To correct, drop off the pressure until the motor runs smoothly.

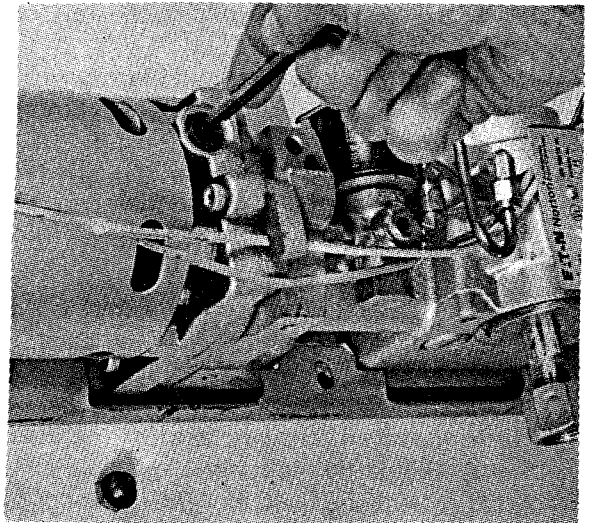

If it has been necessary to increase the pressure to obtain the desired door speed, be sure the door is not dragging on the threshold, floor or mat or it is not binding on the butts or pivots. Recheck these points.

Adjustment and Checkout Limit Switch

Function of Limit Switch

The operation of the motor is to open the door **not** to hold it open. The limit switch is to shut off the motor after opening the door into the backcheck position thus allowing the door to coast to the 90% stop position. The actual point of shut off will vary depending on the weight of the door and the degree of backcheck.

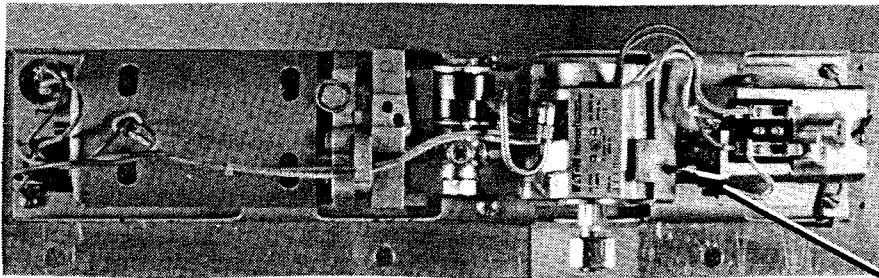
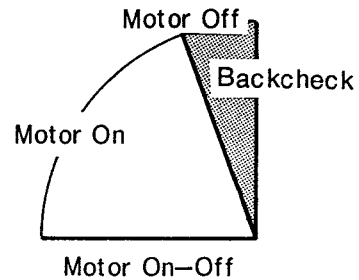

Limit Switch
Adjustment Screw

Adjustment

To adjust- Turn the adjustment screw on the limit switch counterclockwise to decrease motor run. To increase the motor run turn it clockwise. It may be necessary to adjust the backcheck when adjusting the limit switch.

Note: Cam follower and limit switch must have free movement before accurate adjustment can be attained. Also, with the door opened to a full 90% and motor off, the main and secondary arms should form a slight dog leg. If there is no dog leg in the arms, readjust the secondary arm.

Caution- With an improper adjustment of the limit switch and an overrun of the motor, the piston of the operator may travel too far to the end of the cylinder and bottom. This may cause too much pressure against the solenoid valve. Should the door not close, the solenoid valve is locked. **Caution - Do not force the door closed.** Should the solenoid lock, support the body of the solenoid valve and turn the $\frac{3}{4}$ " brass cap nut counterclockwise not more than $1\frac{1}{2}$ turns. This will permit the pressure in the valve to drop sufficiently to let the door close. Retighten cap nut.

After the door is closed, readjust the limit switch turning the screw counterclockwise to cut off the motor sooner. Also the pressure must be readjusted by turning the adjustment screw counterclockwise to reduce the pressure.

Adjustment and Checkout Backcheck

General Information

The Norton operator has a dual backcheck system, 1) a backcheck valve ('BC') which regulates the cushioning of the door to stop position and 2) a positioning valve ('P') which facilitates two (2) starting positions of backcheck.

Valve 'P' should be **open** on regular arm applications. (As shipped from the factory.)

Valve 'P' is **closed** on parallel and slide arm applications. To close, turn adjustment screw 'P' clockwise until it bottoms. **Do not force** the adjustment screw beyond a seated position. To open, turn adjustment screw 'P' counterclockwise until the head is just flush with the surface of the body.

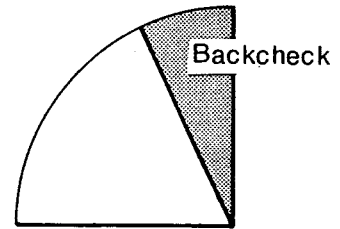

Position 'P' Valve Closed

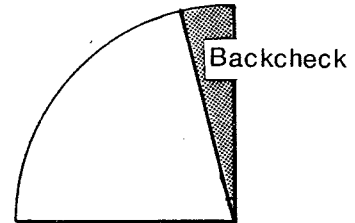

Position 'P' Valve Open

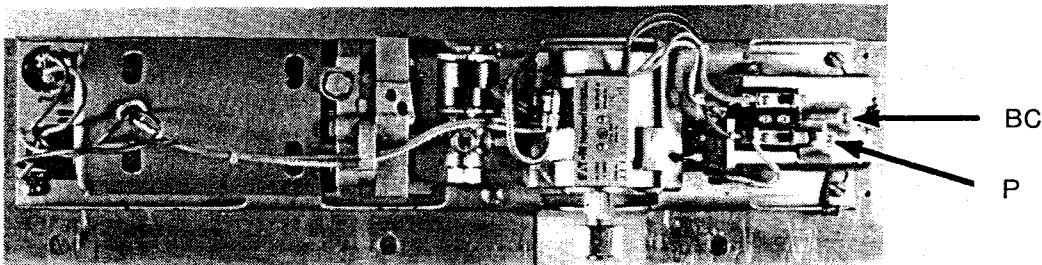

Adjustment

In the opening cycle, if the door seems to labor as it reaches the start of backcheck, turn the 'BC' adjustment screw 1/8 turn counterclockwise to decrease the backcheck. Repeat the procedure until a smooth operation is attained.

If the door opens too fast and 'bounces' when it reaches the full 90° open position, increase the backcheck by turning the 'BC' adjustment screw clockwise.

Note: It may be necessary to reset the limit switch after making the backcheck adjustments.

Heavier and larger doors require greater backcheck and the limit switch must be set so the motor will shut off sooner.

Adjustment and Checkout Sweep and Latch

Door Closing Control

The closing speed of the door is controlled by 1) the sweep valve which controls the major portion of the closing and 2) the latch valve which controls the final portion to latching of the door.

Timing of Door Swing

Time required for the sweep speed shall **not** be **less** than 2 seconds and the latch speed (last 12" of door travel) shall **not** be **less** than 1½ seconds.

When you make adjustments to one, you may find it necessary to adjust the other.

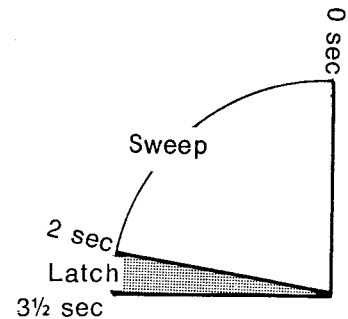

Minimum Closing Speed

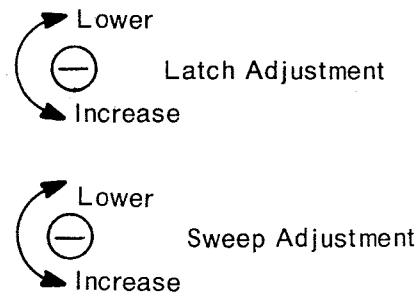
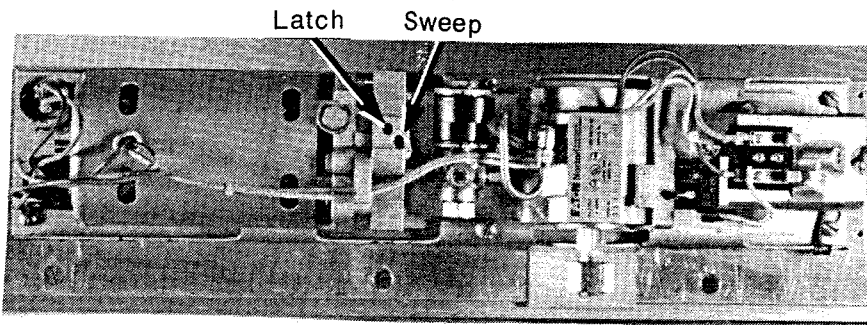

Adjustment

To adjust either the sweep or latch speed, turn the adjustment screw clockwise to lower the speed and counter-clockwise to increase the speed. Move the valve 1/8 to 1/4 of a turn at a time. Recheck door operation after each adjustment. Set adjustments so door comes to a smooth stop without bouncing.

Cover Installation

Important

Before installing the cover, be sure that all wires are secured in such a manner they will not interfere with the operation of the unit or the installation of the cover.

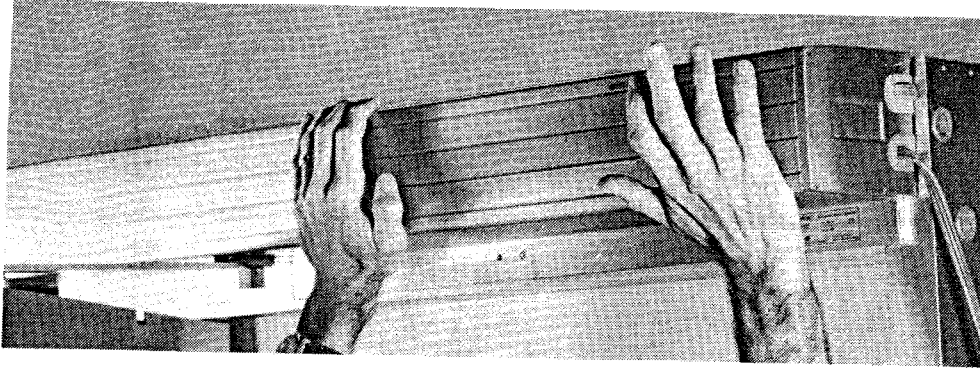

Installing Cover

The cover merely 'snaps on' to the back plate. To install, place cover into position inserting bottom lip into back plate. With a sharp rap upward with the palm of the hand the cover should snap into place. If it does not snap into place, remove and check for interference. After cover has been installed, lock in place using two 1/4-20 x 5/16" Truss head machine screws in the bottom lip of the cover into the back plate.

Note: On regular arm application, the cover is easiest to install when the door is closed. On parallel or slide arm applications, the cover is easiest to install when the door is half open. On operators equipped with parallel panic arms, the two lock screws are replaced with the main arm stop block.

Note: The arm stop block has a tapered side. Be sure the high side of the block is towards the pinon.

After installing the panic arm stop block to the cover it will be necessary to make a minor adjustment to the length of the secondary arm to recenter the door.

Suggestion- loosen set screw and remove secondary rod from sleeve, file flat spot at place of indentation of screw, replace, readjust and tighten.

Final Checkout

As a final checkout, be sure all nuts, bolts and screws are tight and all phases of the operation are operating satisfactorily.

If the door is equipped with a security lock, be sure the lock bolt engages freely in the strike and that the operator holds the door firmly against the door stop.

DO NOT SCALE

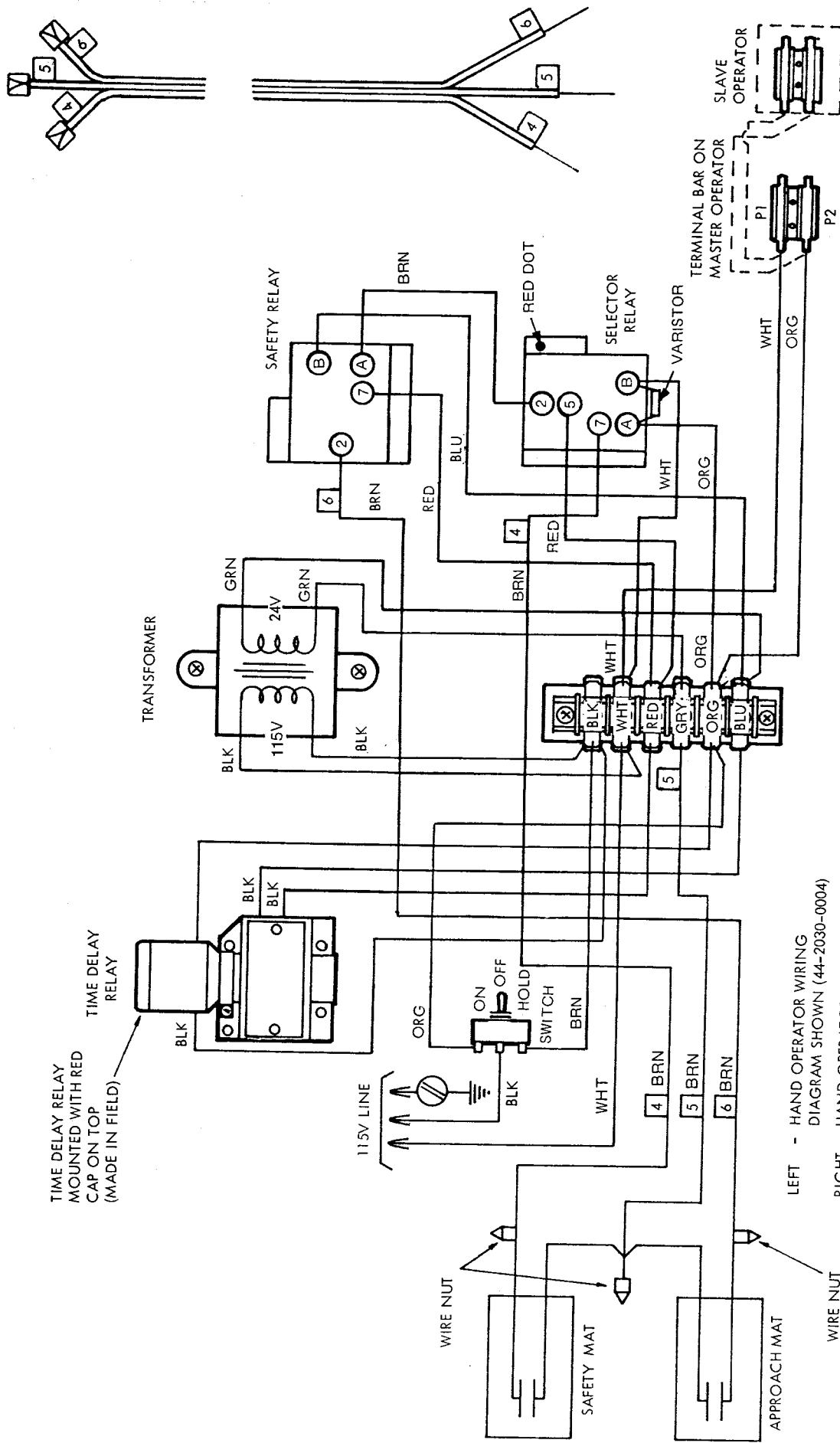

TIME DELAY RELAY MOUNTED WITH RED CAP ON TOP (MADE IN FIELD)

TRANSFORMER

SAFETY RELAY

SAFETY MAT

APPROACH MAT

LEFT - HAND OPERATOR WIRING
DIAGRAM SHOWN (44-2030-0004)
RIGHT - HAND OPERATOR WIRING
DIAGRAM OPPOSITE (44-2030-0007)

EATON
Security Products
& Systems

A-2030 Mat Control Wiring Diagram - Handed

Eaton Corporation
Lock & Hardware Div.
Norton Marketing Dept.
P.O. Box 25288
Charlotte, N.C. 28212

Norton
Door Control Products

Template Drawing No.

Date

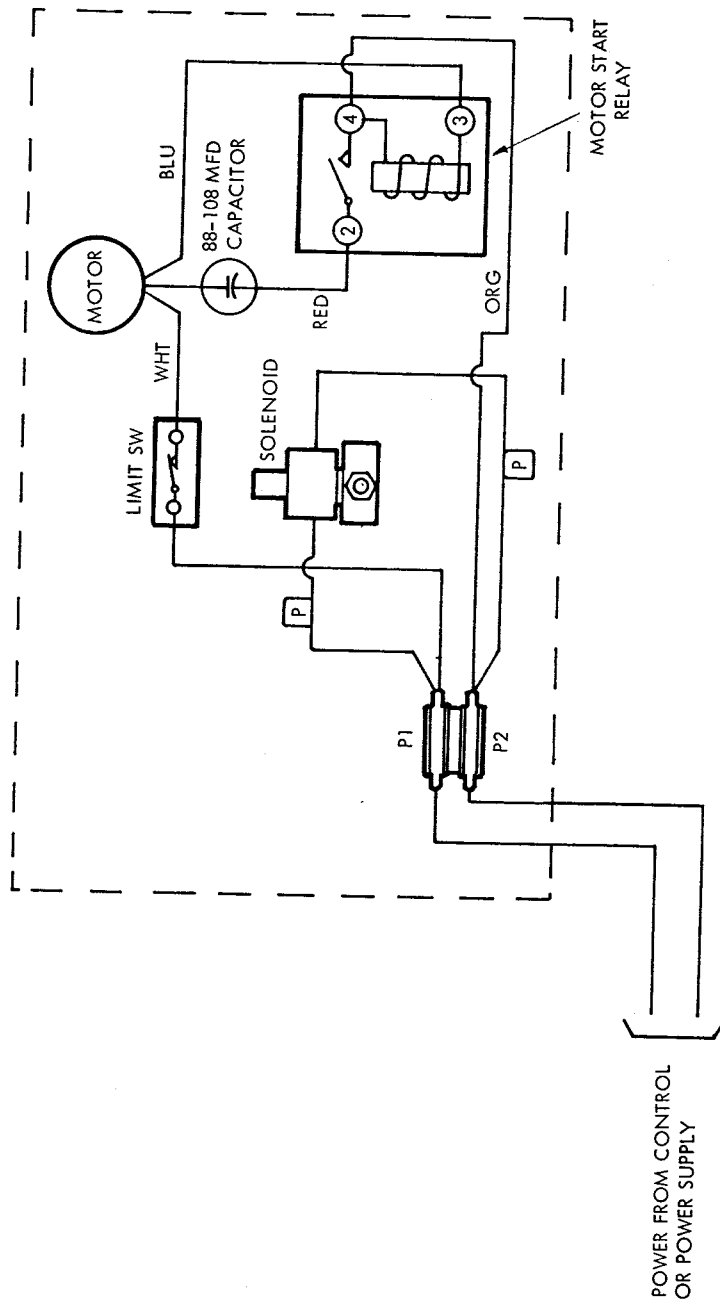

Wiring Diagram for Slave Operator

Eaton Corporation
Lock & Hardware Div.
 Norton Marketing Dept.
 P.O. Box 25288
 Charlotte, N.C. 28212
 (704) 283-2101

Norton®
Door Control Products

Template Drawing No.
WN-5

Date
5-74

2500 OPERATOR ASSEMBLY LEFT HAND SHOWN

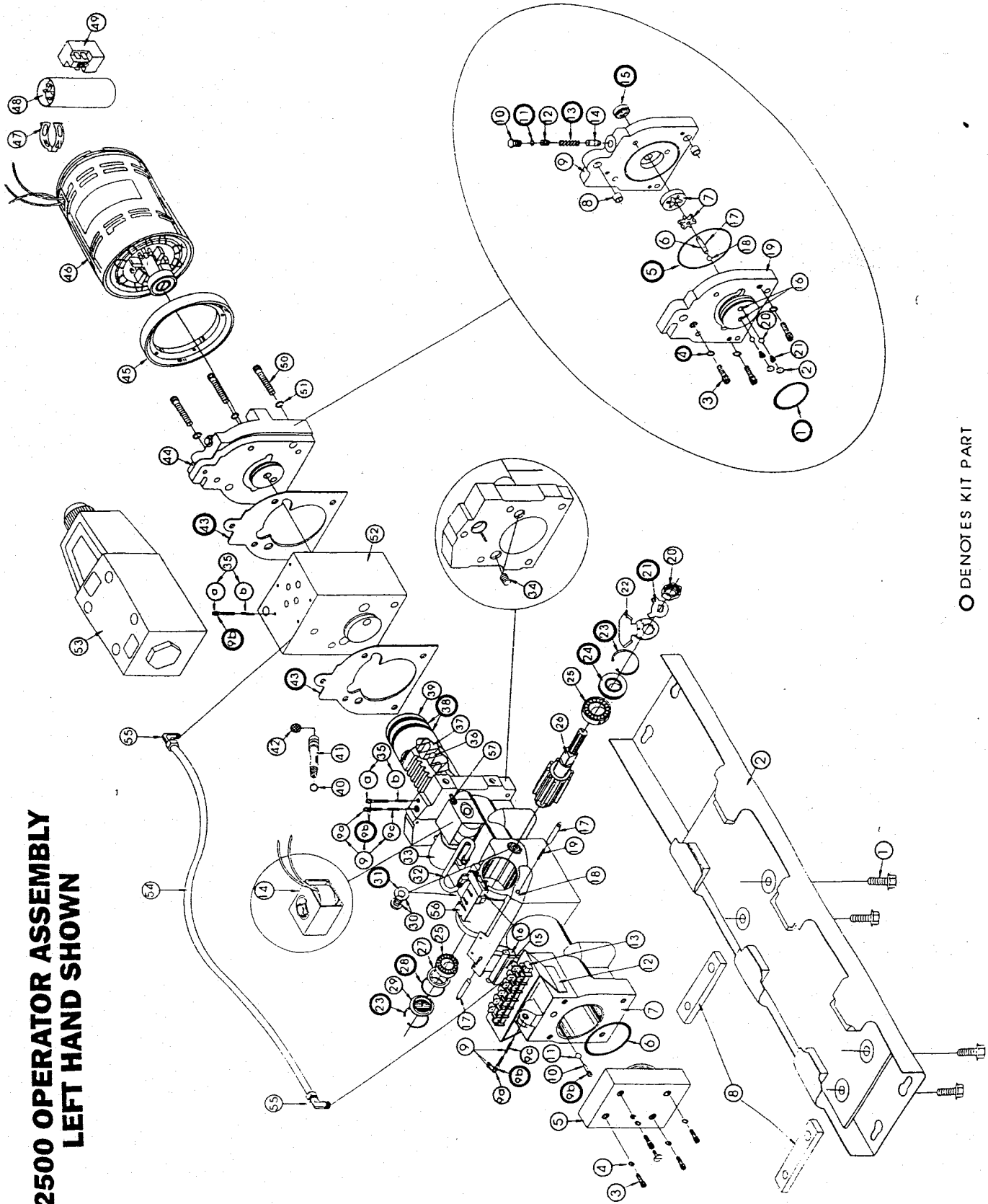

O DENOTES KIT PART

Need Allen wrench
ground
To 4 1/2 ft
Screw on
200

SCREW DOWN TO SLOW CLOSE

SCREW DOWN TO SLOW CLOSE SPEED

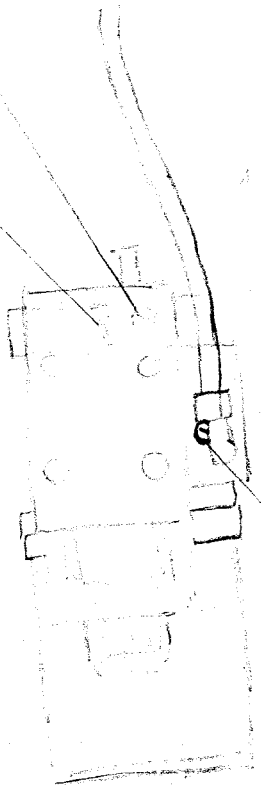

OPEN TO SLOW
DOWN CLOSE PRESSURE